

**TACTILE PAVING DETAIL AT UNCONTROLLED PEDESTRIAN CROSSINGS**

Scale 1:20

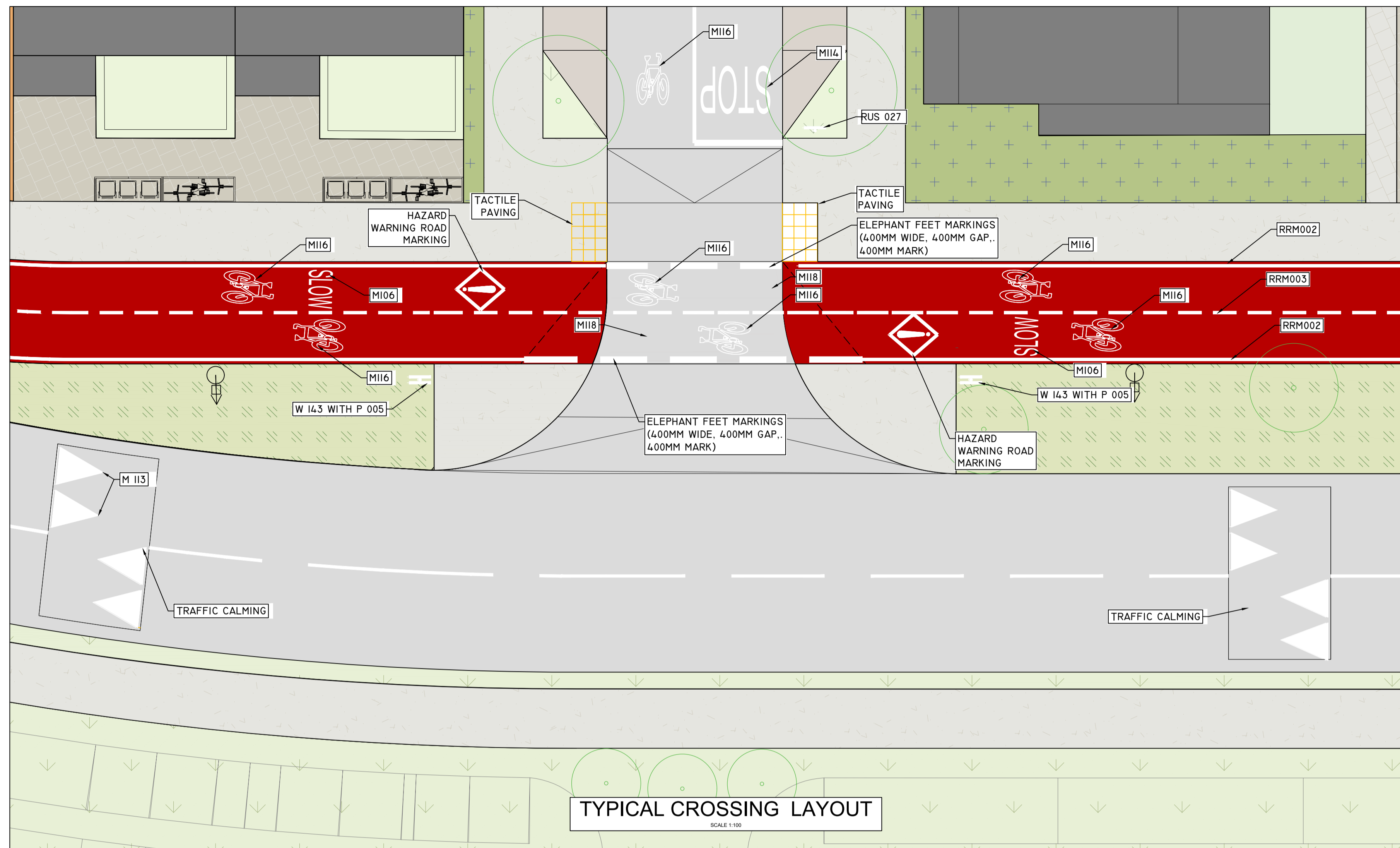

**TYPICAL CROSSING LAYOUT**

Scale 1:100

**GENERAL NOTES**

- DO NOT SCALE THIS DRAWING. WORK ONLY TO FIGURED DIMENSIONS.
- FOR ALL RELEVANT NOTES, REFER TO STRUCTURAL AND CIVIL ENGINEERING PERFORMANCE SPECIFICATION.
- ANY DISCREPANCIES ARE TO BE REPORTED TO PINNACLE CONSULTING ENGINEERS IMMEDIATELY.
- THIS DRAWING IS TO BE READ IN CONJUNCTION WITH ALL OTHER RELEVANT ENGINEERS, ARCHITECTS AND SUB-CONTRACTORS DRAWINGS AND DETAILS.

**RAMP NOTES:**

- 107 MM HDPE SMOOTH SINGLE WALL RED SERVICE DUCT STAMPED PUBLIC LIGHTING TO BE USED FROM LA MIRCOR PILLAR TO CHAMBERS AND RETENTION SOCKETS.
- 50MM OD ED ESB NETWORKS APPROVED RED SERVICE DUCT AT 600MM DEPTH WITH YELLOW ESB APPROVED YELLOW WARNING TAPE AT 300MM DEPTH WITH 10MM DRAW ROPE TO BE USED BETWEEN ESB NETWORKS MINI PILLAR TO LA MICRO PILLAR.
- IF DISTANCE BETWEEN ESB AND LC MICRO PILLAR EXCEEDS 50M, USE I25 RED ESB NETWORKS APPROVED DUCT.
- ALL DUCTS TO BE FINISHED FLUSH WITH ACCESS CHAMBER WALL.

**TACTILE NOTES:**

- THE TACTILE DOMES ON THE TILES MUST BE LINED UP TO GIVE THE DIRECTION OF TRAVEL IN ORDER TO CROSS THE CARRIAGEWAY STRAIGHT
- UTILITY CABINETS/CHAMBERS MUST NOT BE LOCATED WITHIN TACTILE PAVING AREA
- RETENTION SOCKETS TO BE FITTED AT BASE OF ALL SIGNAL POLES. SOCKET ACCESS ORIENTATED SO THAT ACCESS IS GAINED FROM FOOTPATH
- REFER TO TACTILE PAVING GUIDANCE DOCUMENTATION
- MODULE TYPE B (400 x 400MM) ONLY IS SHOWN HERE AND SHALL BE USED IN MOST CASES. OTHER SIZE MODULES MAY BE USED WHERE SITE SPECIFIC CIRCUMSTANCES DICTATE.
- TACTILE BLISTER PAVING SHALL BE BEDDED ON 25MM MOIST SAND / CEMENT MORTAR (3:1). JOINTS FILLED WITH 4:1 MIX WITHIN 2MM OF THE PAVING SURFACE



P02	ISSUED FOR PLANNING	RK	RK	02/09/24
REV	DESCRIPTION	BY	CHK	DATE

CLIENT  
**CAPAMI LTD**

PROJECT  
**OLDCOURT LRD**

DRAWING TITLE  
**ROAD CONSTRUCTION DETAILS  
RAMP DETAILS**

**PINNACLE**  
CONSULTING ENGINEERS

GROSVENOR COURT,  
67A PATRICK STREET,  
DUN LAOGHAIRE,  
COUNTY DUBLIN  
IRELAND. TELEPHONE: +353 1231 1041  
WELWYN GARDEN CITY | NORWICH | LONDON | THE HAGUE

DRAWING STATUS			
<b>PLANNING</b>			
SCALE @ A1	DATE	DRAWN BY	CHECKED
1:1000	OCT'23	RK	RK
DRG NO.	REVISION		
PIN-ZZ-XX-DR-D-I42-SI			P02

COPYRIGHT PINNACLE

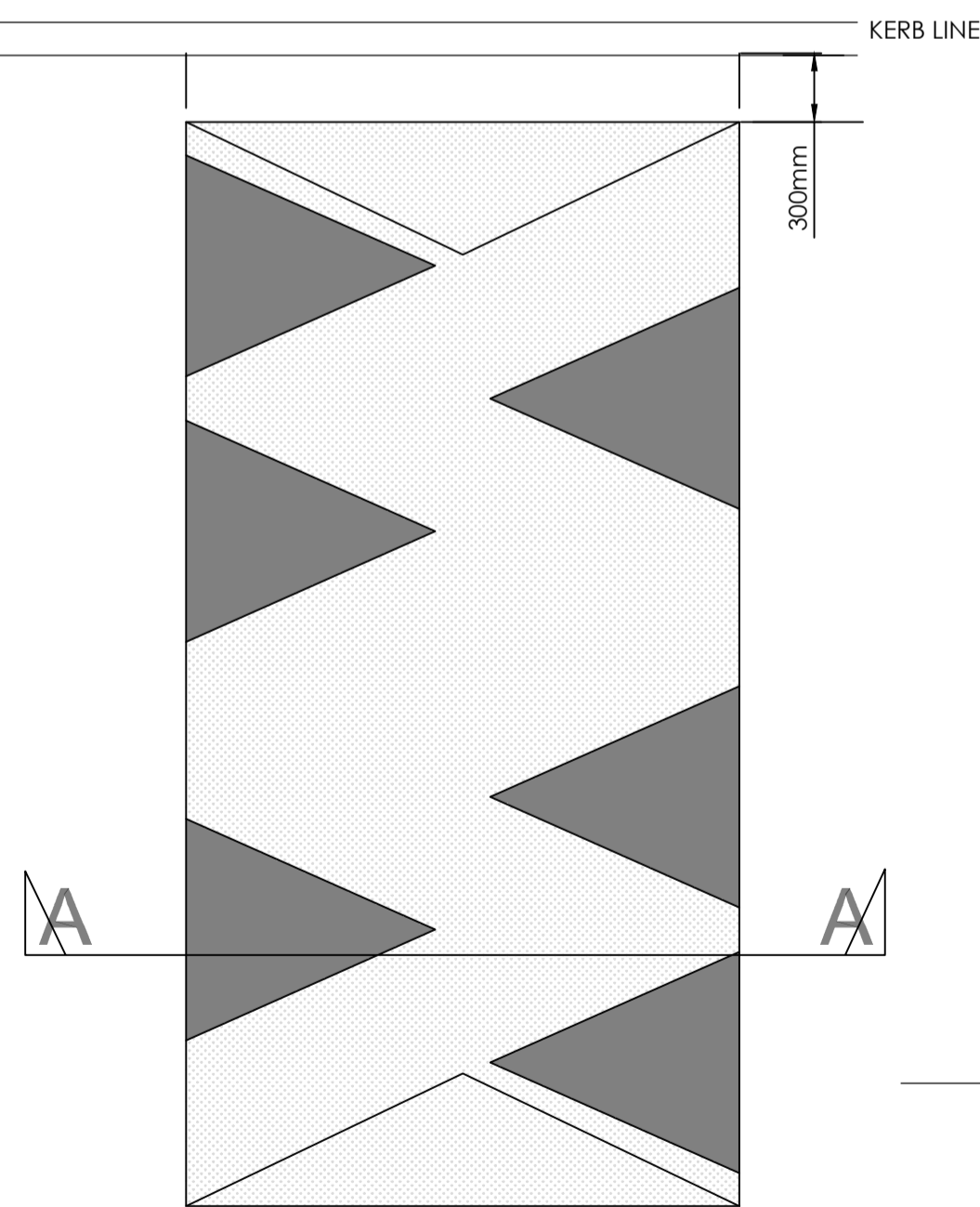

**PLAN**

**SPECIFICATION**  
WEARING COURSE: 35mm OF BLACK SMA WITH 30% RED CHIP OR SIMILAR APPROVED.  
MAXIMUM ENTRY AND EXIT GRADIENT - 1:10  
SIDE GRADIENT - 1:8  
8 No. REFLECTIVE STUDS PER RAMP  
RAMP TO BE PLACED WITHIN 8-10m OF LIGHTING COLUMN.

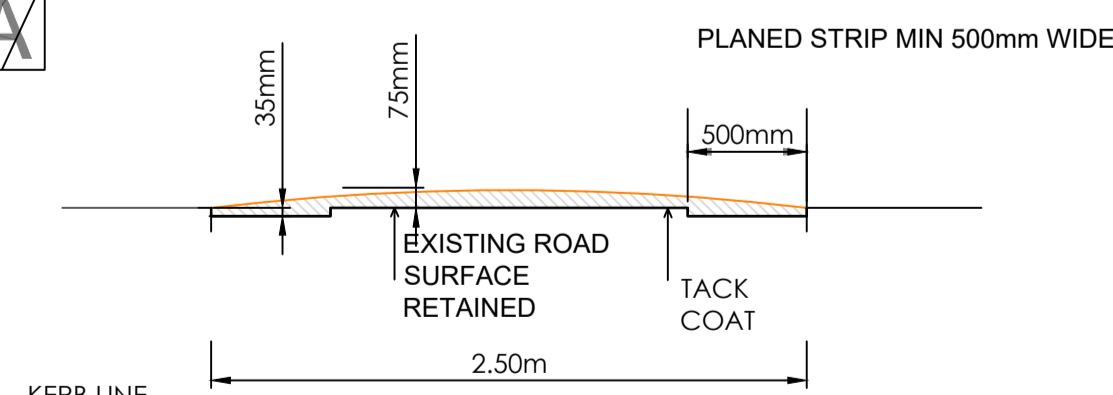

**SECTION A-A**

**TYPICAL TRAFFIC CALMING RAMP LAYOUT**

Scale 1:50

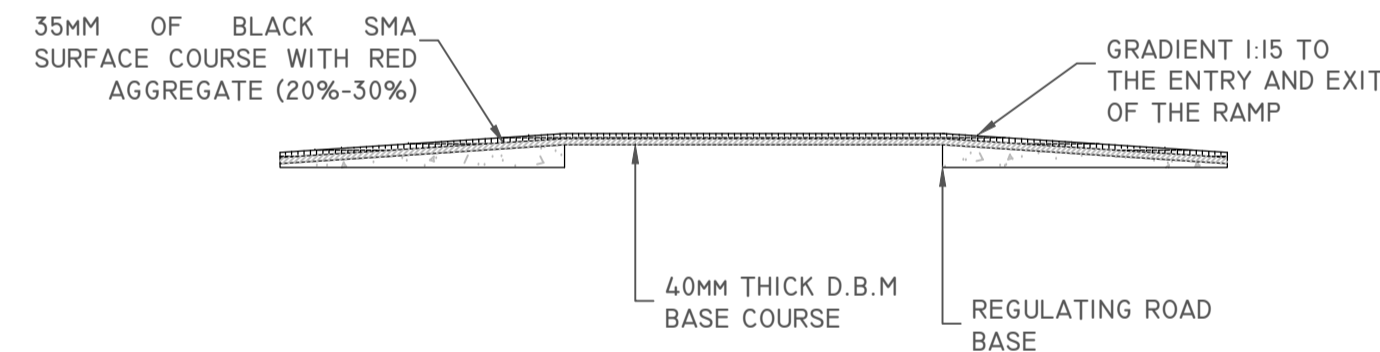

**SECTION A-A**

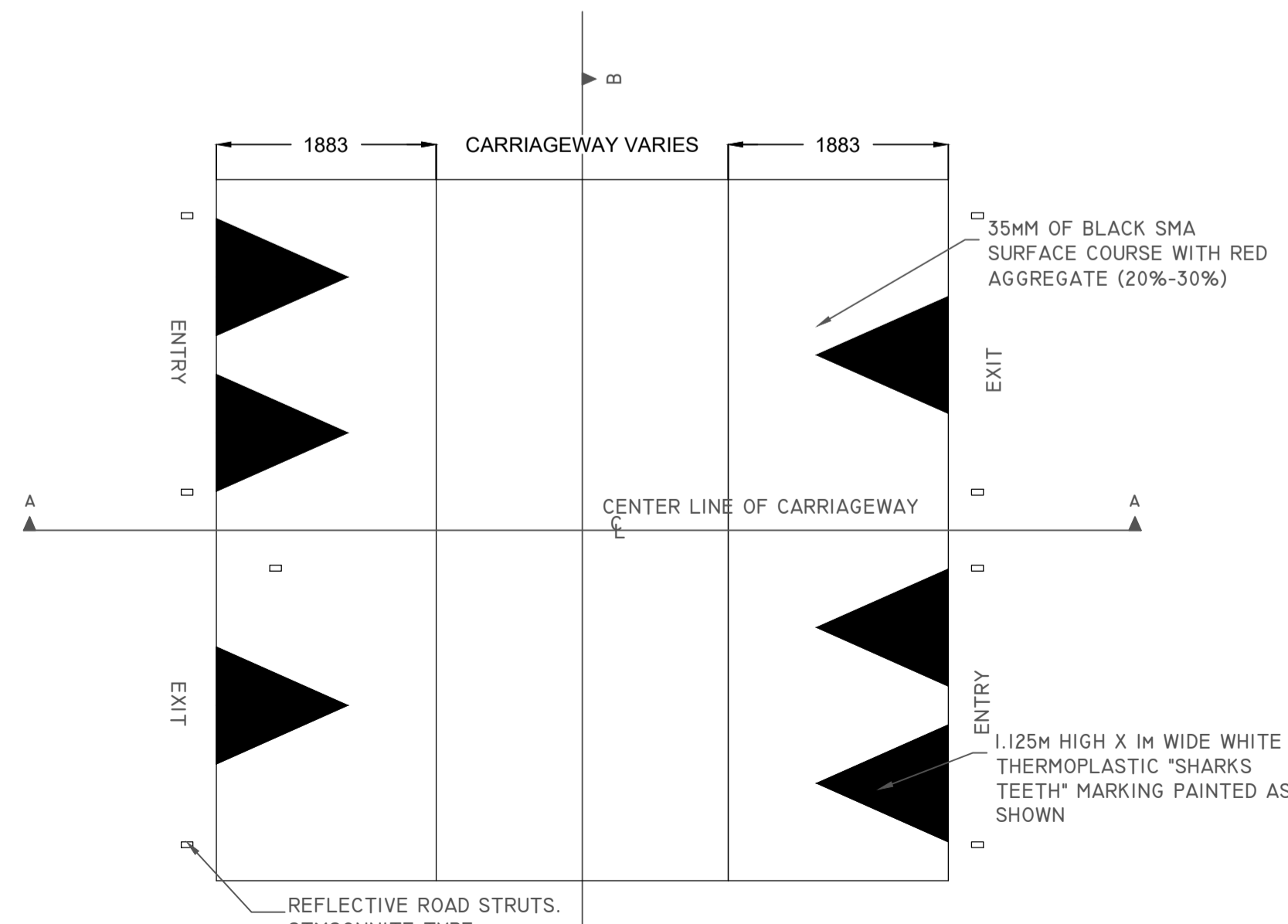

**TYPICAL AT GRADE CROSSING LAYOUT**

Scale 1:50